

MESSAGE TOWER - SPECIFICATIONS

Overall Height 1850mm

- top section 900mm
- middle section 700mm
- plinth 250mm

Base dimensions 884mm x 860mm

Tower width 600mm x 160mm

Screen aperture 395mm x 700mm

(standard colour black(B), white(W) or other colours(C))



Part Number EMT0001(B)
(accessory shown not inc:)

- Includes**
- 1 x set of twin wheel castors
 - 1 x set of adjustable feet
 - 2 x lockable, removable rear vented doors with document holders
 - 1 x earth Kit
 - 2 x ventilated shelves in middle section
 - 1 x acrylic anti-glare screen panel
 - 1 x security anchor bar
 - 1 x assembly fixing kit and assemble instructions

Supplied Flat packed (3 x boxes) for self assembly

MESSAGE TOWER - STANDARD COMPONENT LIST

- 1 x P.C. c/w wireless keyboard and mouse
- 1 x 32" commercial monitor
- 1 x external keyboard shelf
- 1 x set of speakers
- 1 x 4 way power unit with 3mtr Wieland connector to U.K. plug
- 1 x 5mtr Ethernet LAN cable
- 1 x set of internal connecting cables
- 1 x Free of Charge ezeVue Media Manager and 1 x Player Licence
(EzeVue Digital Display software is XP/Vista compatible)

Part Number EMT0001(B/W)(C)

ADDITIONAL SOFTWARE OPTIONS

- Additional ezeVue Media Player Licence **Part Number EMP0001**
- ezeVue Software Support - per player per annum **Part Number EAS0001**

NEW STATIC BASE

Static, low profile base 600mm x 600mm Part No EMTB001

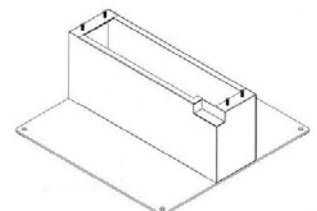

ADDITIONAL - ACCESSORY OPTIONS

Message Tower Mounting Accessories – complete (suffix part number with (B) or (W))

Accessory Bar (required to attach following accessories) *Part No EAB0001*

Literature Bracket – A3 (includes acrylic holder MTA3) *Part No EA30001*

Literature Bracket – A4 (includes acrylic holder MTA4) *Part No EA40001*

Literature Bracket – A5 (includes acrylic holder MTA5) *Part No EA50001*

Blister Display Hook – (supplied in packs of six) *Part No EBP0001*

Shelf Bracket (pair) – (Includes CS1 shelf) *Part No EPS0001*

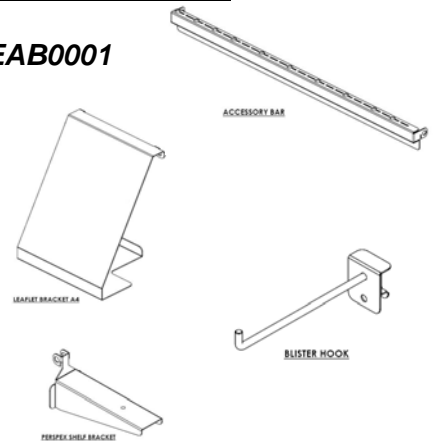

Replacement Plastic Mounting Accessories

Clear Shelf – 200x600x30mm (use 829248 bracket) *Part No CS1*

A3 Acrylic Holder – (use 829296 bracket) *Part No MTA3*

A4 Acrylic Holder – (use 829297 bracket) *Part No MTA4*

A5 Acrylic Holder – (use 829295 bracket) *Part No MTA5*

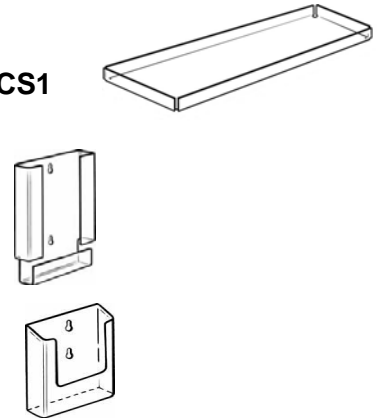

Leaflet dispensers can be used in the following combinations on each Message Tower:-

- 1 x A3
- 2 x A4
- 2 x A5 & 1 x A4
- 3 x A5

WARRANTY & UPGRADE

Standard Warranty

12 Month Warranty on Message Tower casing and all passive components
 PC 1 year on site. Monitor 1 year return to base (2 week service /collect –repair- return)
 ezeVue supplied with free version updates.

Upgraded Warranty

Annual Support Contract – includes 12 months support on ezeVue, 48 hour monitor replacement service and an annual site visit includes PC Check/Clean. Part No EMTAS0001

Onsite Services

Delivery & Onsite Assembly Part No EAOT0001
 ezeVue Training ½ day Part No ECIT0002
 ezeVue Training full day Part No ECIT0001